

On a Fringe Movement Registered on a Platform in Uniform Motion (1942).

A. Dufour and F. Prunier J. de Physique. Radium 3 , 9 (1942) 153-162

Abstract

In a first series of experiments, described herein, we used an optical circuit entirely fixed to the rotating platform as in previous work Sagnac. Under these conditions we found that the movement of fringes observed are similar within 6%, whether the light source and photographic receiver be dragged in the rotation of the platform, as in experiments Sagnac, or they remain fixed in the laboratory. The second series of experiments described here was aimed to explore the fringe displacement due to rotation, in entirely new conditions characterized by the fact that the optical circuit of the two superimposed interfering beams is composed of two parts in series, one of which remains fixed in relation to the laboratory while the other is attached to the rotating platform. Moving fringes, obtained under these new conditions, were the one that allows for the classical theory. Where the optical circuit is fully fixed to the rotating disc, as in Sagnac's experiments, the observer does not have the means to make a choice between the interpretations of the placement of fringe data obtained by the theory of the classical theorists and that of the relativists. But, where there is a part of the circuit which remains fixed in relation to the laboratory, the relativist theoretician can not agree with the classical theorist, nor with the results observed, assuming, as had done until now, that the centre, where the observer must presume to be positioned to calculate the experience can be arbitrarily chosen on the rotating platform. This centre must be colinear with the centre of rotation of the platform.

I. -- Experiments in which the Optical circuit is entirely supported on a Rotary platform.

1. Preliminary experiments. – So that we could familiarize ourselves with the experimental difficulties, we first of all have repeated the experience of Sagnac [1] in which all the optical apparatus is, as we know, moving with the disk in uniform rotation. We used to that end, the same mirrors which had been used by Sagnac in his experiment, but the platform that we used was twice as large as his. It had here 1m in diameter and could turn at a measurable speed, not exceeding however, 5 rotations / sec, in a direction, then in another, around its axis of revolution standing upright. This axis was defined by the line through the final points of the rigid tree supporting the disc, points swivelling in cups in grease pans carried by a solid frame sealed with the wall of the laboratory. The assembly removed any play during rotation of the apparatus and allowed however the easy maintenance of its movement without harmful vibrations.

The torque was supplied by a small dynamo set at the same wall; transmission of this couple was obtained through a belt acting on a pulley connected with the tree of the platform. This material arrangement has remained the same for all experiments that will be discussed here. Figure i gives the layout of optical apparatus straddling the entire disc and used in these preliminary tests. It is close to identical to that of Sagnac and does nothing original. The separator used by Sagnac could not be found and has been replaced here by the beamsplitter, separating the receiver R, not silver plated, and receiving the rays under a rather large incidence.

The end of the light source through the S-collimator comprised of the entire lens L and diaphragm o in its housing and then, upon reflection auxiliary m, has given the two beams interfering which split in C, at the center of the disk, to go in opposite directions, one path C MM'M"C and the other the path C M""M"M'MC.

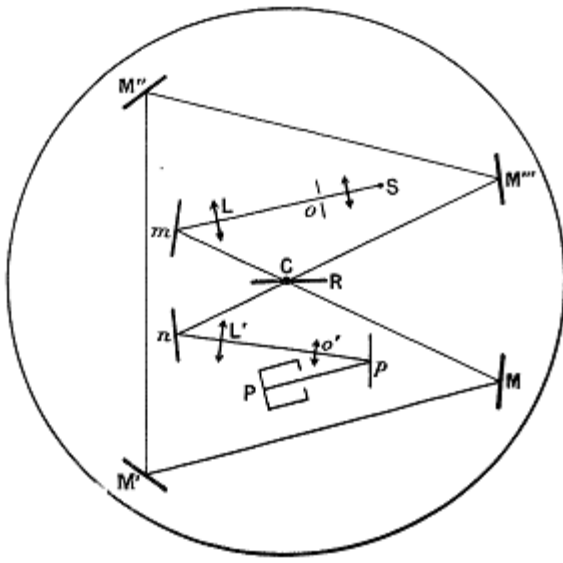

Fig. 1.

After their meeting out of C, these beams are returned by auxiliary mirror n to the lens o' which makes it possible to obtain, after a last auxiliary reflexion out of p, the real fringes on the photographic plate P.

In consequence of the low intensity available on photographic plate, we almost always have had to operate in white light with Agfa panchromatic plates of great sensitivity. It results from this that measurements of displacements of fringes made on all our photos are obviously affected by not very important errors and variables in connection with the spectral composition of the light used and with the selective sensitivity of the emulsions of the various series of plates for the various wavelengths.

In spite of this imperfection, the significance of the results obtained remains whole here from the qualitative point of view. Moreover, even from the quantitative point of view, the extreme variations of the numerical results of even one series of recordings never exceeded 13 per 100 of the median value, the order of magnitude of this one thus remain valid and significant.

The experiments made with the device of figure 1 were precisely used by us to calibrate the indications of the photographic recordings according to the value of the Sagnac effect in white light for the particular plates which we used.

For each direction of rotation, the exposure time was of a fraction of a second. The determination of the number of constant revolutions during the exposure was obtained by the measurement of the number of revolutions of the platform during 2 min with a stopwatch.. One recorded the plate fringes obtained, initially for one direction of rotation, then for the other direction. The magnetic remote activation of two small shutters made it possible to protect successively each half of the plate against the action from the light. One thus obtained the two systems of fringes corresponding to the two separate directions of rotation one of the other by a fine line facilitating their comparison. The measurement of the distances between interference fringes and the shift of the fringes was taken by pointing a dividing machine (a machine for drawing precise equidistant lines).

The average of nine recordings of the ordinary Sagnac effect gave us a value for this effect of 0.082 as the distance between interference fringes for an angular velocity of 1 turn/sec for the two directions of rotation, the source of light being the filament of a fairly good incandescent lamp.

The order of magnitude thus observed for the ordinary Sagnac effect appears well in agreement with that one could envisage by taking account of the position of the approximate centre of gravity in the spectrum, and of the action of the light on the panchromatic plates used; besides this centre of gravity defines the effective wavelength for the calculation of the phenomenon. In the formula of Sagnac, which gives in fraction of distance between interference fringes the value δ of the total fringe shift for the two directions of rotation:

$$\delta = \frac{16\pi NA}{C\lambda}$$

N is the number of revolutions/sec of the platform, A is the value of the area of the path closed by C MM'M''C of figure I, C is speed of light and λ the wavelength used. In our experiments, the surface area was approximately 2840 cm². The experimental results obtained have thus given us licence to deduce that the wavelength λ has a value of approximately 0.57 μ m when the source is consisted an average incandescent filament fairly pushed, 0.54 μ m if it is more brilliant, 0.45 μ m if this white light crossed a Schott screen out of blue glass, letting pass only the region of the spectrum going from 0.5 to 0.36 μ m.

2. Experiments made with a source of light remaining fixed in the laboratory. –

The first question that we considered was to determine if the movement of the source that creates the light is essential to the production of the phenomenon. We then constructed the apparatus as shown in the diagram of figure 2. The characteristics of this assembly are to use the light of a fixed source in the laboratory and to send this light on the optical courses fixed to the platform in rotation, in the shape of flashes repeating itself with each turn of the disc when it passes in the same position.

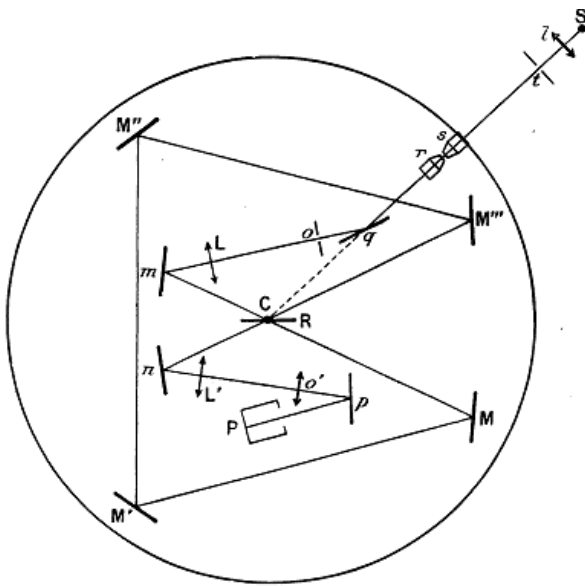

Fig. 2.

For this purpose, the light resulting from the source S will traverse the lens l, the diaphragm t and the microscope objective s, all these bodies being maintained fixed to the laboratory. Another microscope objective r identical to the first, is fixed to the revolving platform and projects an image of the diaphragm o, thanks to the auxiliary mirror q, an image on the diaphragm t equal with o, when the platform has precisely the position indicated in the figure. The S srq line is directed so that its extension passes through the center C of rotation, so that the objectives r and s work under good conditions at the time of the flash.

If v is the linear velocity of the objective r and g its magnification, the linear velocity of the image diaphragm t on the diaphragm o will have a value approaching vg. The duration τ of the flash will thus be of the order $\tau = vg / d$ if d is the diameter, here common, diaphragms o and t. In our experiments, Cr = 45 cm, g = 10, d = 1.5mm, which gives, for an angular velocity of 4 turns/sec, $\tau = 1.3 \times 10^{-5}$ seconds approximately.

Thus, even at this speed, each flash, the duration t of the useful beam of light is quite high at the run time of the light along the circuit optics. This one has, indeed, approximately 3 m length; it is consequently traversed by the light in 10-8 seconds. Each beam thus makes at least 1300 times its turn of the optical circuit during a flash. Fringes thus have a large time to be formed on the photographic plate. However, to obtain one sufficient photographic impression under these experimental conditions, the installations will have to be longer than in the case of the trained source. It has been necessary to wait approximately 5 min here for each direction of rotation, by using the same source of white light as that above.

The recordings which we carried out thus show a net shift of the fringes completely comparable with that provided by the traditional assembly of Sagnac. The average of the results of measurements made on a series of nine photographs led to the value 0.088 distance between interference fringes for the shift of the fringes corresponding to the two directions of rotation and one angular of the platform of 1 turn/second velocity. The variations of the individual results reach to the more 15 / 100 of this average. It is seen that to 5 or 6 per 100 close, the average shift observed is of the same value here than that obtained above with the ordinary assembly of Sagnac.

Specimens of recordings reproduced here in figure 3 represent, increased four times two of the original photographs. Directions of rotation relative respectively to the upper parts and lower of the same photographs are opposite. stereotype 57 (number of revolutions 4.13 turns/second) watch the Sagnac effect obtained with the traditional device or the source is pulled by the disc photograph 45 (number of revolutions 4.39 turns/second) is a recording obtained under the current conditions, i.e. when the source is fixed in the laboratory. One sees that the shift of the fringes is appreciable even in these two tests.

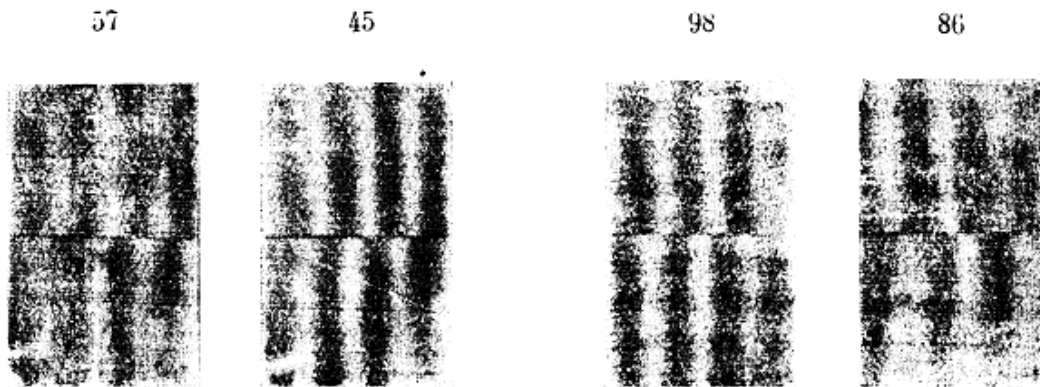

Fig. 3.

Fig. 4.

In short, these last experiments show that it is possible to practically use the light emitted by a source not belonging to the mobile disc system, at the time of the study of the propagation of the light on this disc for an induced observer in rotation, notable although rather slow, platform, without that the experimental results are modified for him in a noticeable way.

3. Experiments made by using a source and a photographic recorder remaining fixed in the laboratory. –

One could ask whether the interferential phenomenon remains the same one for the observer fixed in rotation and for an observer maintained fixed in the laboratory frame.

To carry out this study, the device represented schematically in figure 2 underwent the following modifications: the mirror p was removed, the objective lenses L' and the eyepiece o' as well as the photographic chamber P were removed from the platform and fixed at a support motionless with the seal of the wall of the laboratory, in such a manner as to be placed in a straight line at the places suitable on the path of the reflected light by the mirror N at the time of the flash. In this arrangement, the source of light and the observer operating the photography of the fringes with the lenses and photographic chamber, are both fixed in the laboratory.

But throughout flash, very short though nonnull, the platform turned a small angle and the fringes obtained on the photographic plate underwent a light modification because the lens and plate are motionless, while the interferometer is turning. To eliminate from this measurement any possible cause of error, we used the known change of sign of the Sagnac effect when one swivels a small angle S around a vertical axis separating ice R on both sides of its average position providing the central fringe extended in all the interferential field. For the photographs obtained when the angle is positive, the shift of the fringes due to the rotation of the interferometer during the flash will be added, for example, with the Sagnac effect. On the contrary, for photographs obtained when the angle ε is negative, the shift of the fringes due to rotation will be cut off from the Sagnac effect. By taking the average of these two series recordings, a value of the Sagnac effect will be obtained corresponding to one negligible duration of the flash. Naturally, the

precision of the results suffers a little this additional difficulty. In spite of this, the values found remain similar to the preceding ones. Thus the average of the shift of the fringes given by ten stereotypes in each series for the two directions of rotation and an angular velocity of 1 turn/second is equal to 0.098 distance between interference fringes for a certain sign of ϵ , and to 0,084 distance between interference fringes for the other sign of ϵ . The average of these two values is 0.091 distance between interference fringes, differing only from 3 to 4 /100 of the number obtained previously if the source of light were fixed in the laboratory.

Photographs 98 and 86 (angular velocity of approximately 3.7 turns/second), given in the figure 4, represent increased four times, two of the original photographs obtained under these conditions, and for which the direction of rotation of the platform is the same one in what relates to the higher areas of the recordings; for the lower parts of these photographs the direction of rotation is opposite to that previous . The angle ϵ was of a certain sign for photograph 86, of the sign opposite for photograph 98. One realizes, at first sight, that the average of the absolute values shifts of fringes on stereotypes 86 and 98 is of the same order of magnitude as the shift of fringes detected by stereotype 45 of figure 3. This result is related to the fact that the platform turns of a very small angle throughout flash.

I I. - Experiments in the which optical circuit includes, in series, a fixed part in the laboratory and, a part pulled by the platform in rotation.

1. Preliminary tests. - Figure 5 gives, in perspective, the diagram of the first device which we tested.

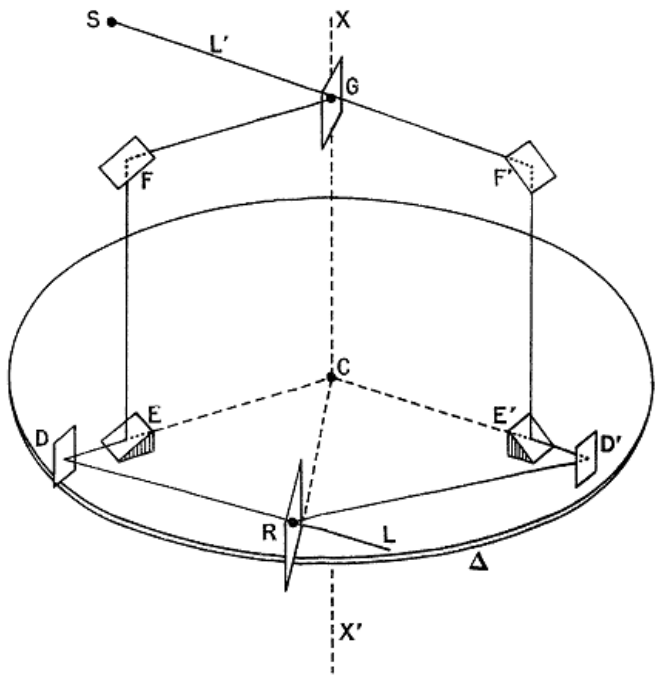

Fig. 5.

The light resulting from the source S crosses the collimator L' (not drawn) and comes to provide, by the action of separating beamsplitter G, the two interfering beams with distinct paths, one path GFEDR and the other path GF'E'D'R. The fringes are observed in the lenses L.

The source S, the collimator L' and the mirrors G, F, F' are fixed in the laboratory. Other mirrors, as well as the lenses L and the photographic plate are carried by the platform and turn with it. Consequently, only portions EDR and E'D'R of the light path is fixed on the disc in rotation. Lastly, the provision of the mirrors is supposed perfectly symmetrical compared to the plan GCR in which line CG is colinear with the axis of rotation XX' of the disc. The experiment carried out in accordance with this assembly could not lead to effective recordings, because it was necessary to operate in monochromatic light of which the intensity would have been insufficient to impress here the plate without excessive durations of installation, and especially because small ground vibrations scrambled the system of fringes, which would have removed any significance in the discussion of results.

2. Device actually used. –

The preceding disadvantages resulted owing to the fact that the two interfering beams followed distinct paths. They disappeared when we obliged the two beams to follow the same course in opposite directions. Figure 6 gives, in perspective, the diagram of the apparatus construction which was useful to us.

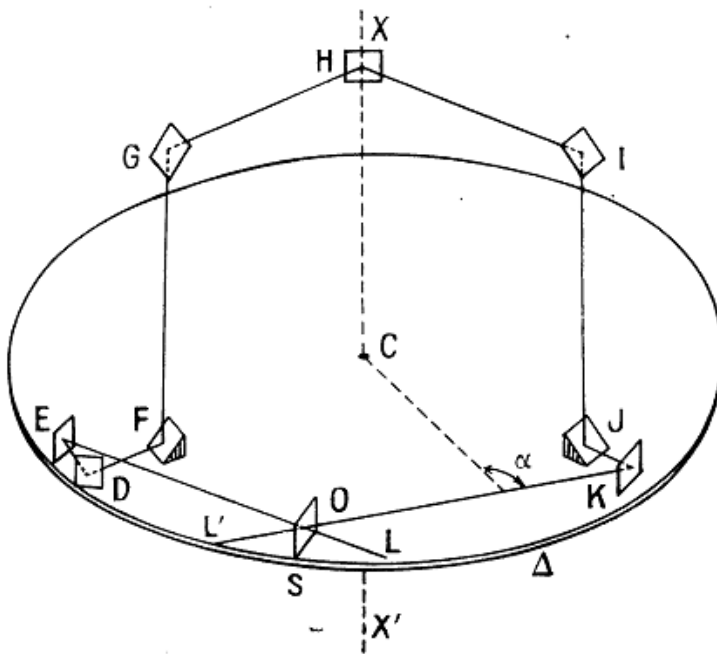

Fig. 6.

The collimator L' and the lenses L (not drawn), the beamsplitter S (separating and receiving) where observer O is supposed to be, the plane mirrors K, J, D, E, F are all fixed on the platform and turn with it. The beamsplitter planes S is about at equal distance to the mirrors F and J. In addition, radial lengths CF and CJ are equal between them.

Mirrors G, H, I remain fixed in the laboratory. For all the mirrors other than F, G, I, J, the planes of incidence are horizontal, parallel to the platform.

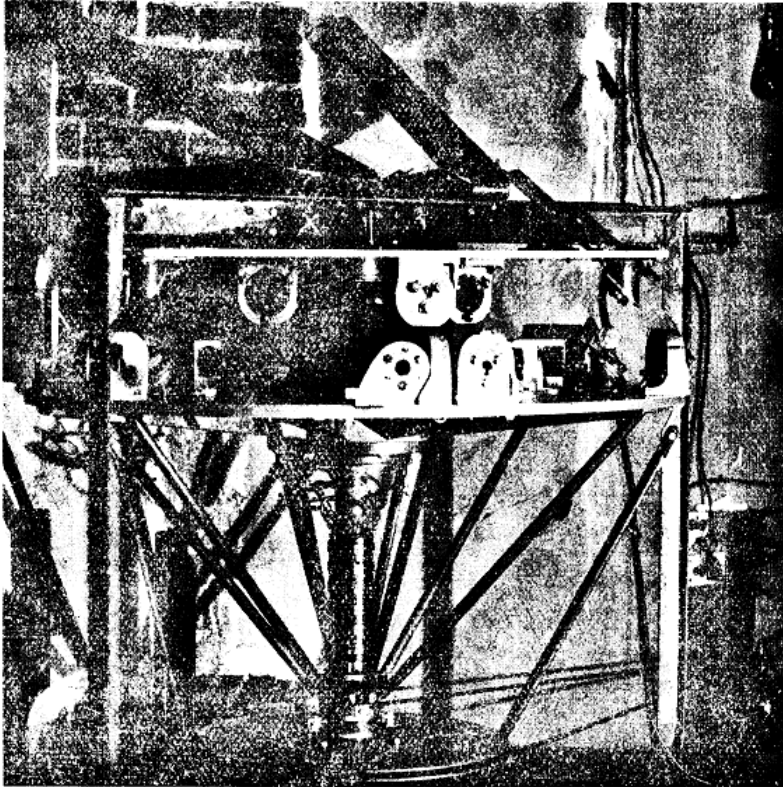

Fig. 7.

Only the planes of incidence of the mirrors F, G, I, J are vertical and contain the axis of rotation XCX' . These last mirrors are tilted to 45 deg. on the vertical, the mirror F being parallel with the mirror G, and the mirror J parallel with mirror I at the time of the flash of white light provided by a source (not drawn), fixed in the laboratory and consisting of a carbon arc. Lastly, lengths FG and IJ are parallel to the axis of rotation, equal between them and of value 10 cm.

One of the interfering beams follows the path SKJ, on the disc, then JIHGF (path remaining fixed in the laboratory), and returns by the path FDES carried out on the disc. The other beam goes in the opposite direction on the same path. The fringes are recorded on a photographic plate related to the platform Δ and located in the focal plane of the lens L. Figure 7 is a photograph of the experimental device such as it was used by us. The source of light is not visible there, being to the left, out of the field. The turning disc, of vertical axis, is surmounted by one second platform fixed at the frame sealed with the wall of the laboratory and which carries the mirrors of the upper floor. Those are, actually, five and not three like figure 6 indicates. Indeed, it is obviously impossible to place a plane mirror H fixed on the axis of rotation of the revolving platform, this single mirror H was replaced, in fact, by three plane mirrors which one sees in figure 7 and which makes it possible for the interfering beams to circumvent the tree of the mobile platform, not to be intercepted by it. But as the higher course of the beams is fixed in the laboratory, and that azimuths of the planes of incidence of the mirrors G, I remained

unchanged, it is more convenient to use in the reasoning (and it is what we will do), the plane mirror fictitious H figure 6, to replace the three mirrors fixed in the reality of figure 7 which are equivalent to it in the experiment.

One can wonder however if it is reasonable to hope to obtain fringes usable with such an interferometer that is already rather complicated and of which the two parts are moving relative to one another. It is thus necessary, even required, to manage to obtain sufficiently definite fringes, remaining unchanged throughout this flash, in spite of the movement of the revolving platform. These two conditions could be satisfied in constituting the upper floor of the device by one odd number of plane mirrors and by equipping the apparatus with the additional plane mirror D. Below are the reasons for having such provisions: --

1° For the short length of time (but nonnull) of the flash during the rotation of the platform, the direction of the incidental beam of light does not change hardly, but the mirrors F and J fixed on the turning disc move a little compared to beams which they respectively receive from the upper floor. However, the fringes used are ad infinitum localised and each one of them is provided by a whole group of rays. So that these fringes do not undergo modifications, it is necessary that the whole of the rays of each interfering beam remains in same relative positions compared to the mirrors that they meet, a condition which particularly relates to the mirrors with 45° (F and J) fixed on the revolving plate. However, if one observes in J the luminous spot provided by the beam going in direction of F to G towards J, and the luminous spot out of F provided by the beam going in contrary direction J with I towards F, one notes that these luminous spots move a little in consequence of the rotation of the mobile platform Δ , and in opposite directions when the fictitious mirror H is replaced by a number of plane mirrors, two for example, to transmit the light of G at I and I to G. In such conditions, one can obtain fringes (mirror D being then supposed to be non-existent), but these fringes narrow or widen according to direction of rotation, even when very slow. These modifications of fringes result owing to the fact that the group from the light rays do not meet each mirror F and J always in the same relative positions during the platform rotation.

But if the optical course of G with I and I to G is carried out this time in the upper floor by an odd number of plane mirrors, there is a direction change of displacement out of F or J for one of beams, so that throughout the flash, the areas of arrival of the beam X on the mirrors F and J accompany the latter well during their rotation. And the fringes which one obtains then (mirror D being supposed positioned back, one will see further why) remain unchanged during lasted of the flash if the number of revolutions is négligible, as shows it photograph 142 (increased here approximately four times) of the figure G.

2° If the plane mirror D did not exist, the number of mirrors located on the light path would be odd, here equal to 9; and it is known that in this type of interferometer, the number of the mirrors must be even so that the corresponding rays are found on the beamsplitter. The presence of this mirror is thus necessary so that the rays which separated with various points of the beamsplitter do not provide their return on this beamsplitter two beams turned over one compared to each other.

3° But the existence of the additional mirror D is made compulsory for another reason: its role is also to compensate for the modification of the points of impact of the rays on the mirrors F and J at 45°, this modification being due to the displacement of these mirrors throughout the path of the light above the mobile platform, in the upper floor carried by another fixed platform in the laboratory.

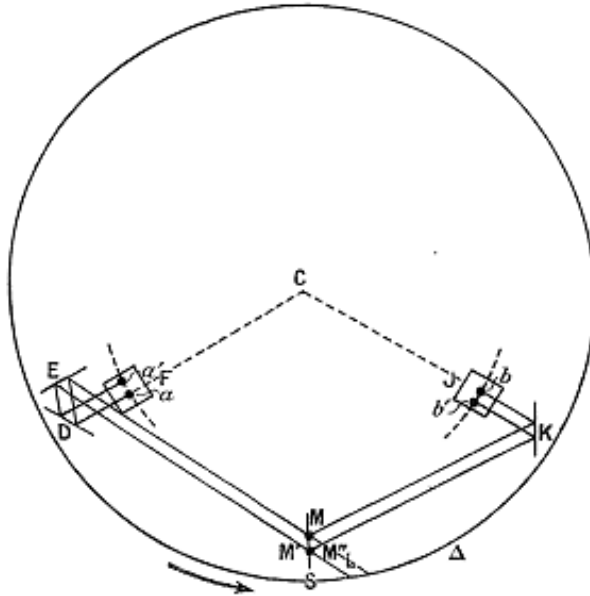

Fig. 8.

Figure 8 represents, for this purpose, the revolving platform seen in plane. Points a and b are marked at their respective starting and arrival points of the interfering, here the beams are shown with only one ray, the motionless platform being shown, and the adjustment being such as the rays on return coming from an incident ray come to be cut on the separating beamsplitter. Under these conditions, the ray circulating in the direction starting from M , arrives on the mirror F , goes up to the upper floor, goes down again out of B on the mirror J and returns in M . The ray circulating in the opposite direction arrives out of B on the mirror J , goes up to the upper floor, goes down again to the mirror F and returns in M . The corresponding fringe is seen in direction ML .

Let us suppose now that the disc Δ is given an angular velocity ω in the direction indicated by the arrow. Points a and b , in these new conditions, are still the respective starting points of the interfering rays moving towards the upper floor. Let us make an abstraction for the moment in what follows, from what can occur in this higher course from the rays. During the journey time of the light outwards on disc Δ , it will have turned a certain angle.

The ray starting from a will not return any more out of b , but out of b' on the mirror J and will then follow the path $b' KM'$ traced on platform Δ . The ray starting from b towards the upper floor will not return via a , but via a' on the mirror F , and will then follow the path $a' DEM''$ traced on the platform Δ . If the separating beamsplitter is at equal distance from the mirrors F and J , one has $aa' = bb'$.

It is worth remarking that the returning rays maintain the same direction, provided they follow the paths traced on the platform Δ , whether this platform is turning or not. From this parallelism and the condition $aa' = bb'$, one deduces that the rays returning from b' KIVI' and a' DEM" cut the separating beamsplitter at the same point, so that M' and M'' are conlinear. It also results from this that the corresponding fringe ad infinitum remains, on disc Δ , in same direction ML as when the platform was motionless. But the question which arises at once is whether the aspect of the fringe has remained unchanged. Two assumptions are then to be considered:

First assumption. – the speed of light on the platform remains constant and equal to C , whether this platform is motionless or moving. The light frequency preserving on the disc one constant value, one deduces, in this case, in light of the parallelism noted above, that the return rays arriving in M' M'' are, opposite one another, under the same relative conditions of phase as if the platform did not turn. It results from this that fringes recorded by the photographic plate are modified neither in aspect, nor in position by the act of the rotation of the platform Δ .

Second assumption. - The light propagation velocity on the revolving platform depends on the direction in which it travels. In this case, the travel of the rays, traced on the platform, does not change admittedly but a new factor intervenes: it is the delay brought between the light rays by the inequality of speeds of light propagation, a delay which modifies the order of interference of the fringe laid in the remaining direction, however constant ML . This would result effectively in an equivalent displacement of the fringes on the photographic plate.

But, ultimately, it is seen that, in these two assumptions, changing the positions of the points of return a' and b' of the rays, resulting from rotation, may not, by itself, cause any changes in appearance or position of the fringes on the photographic plate fixed on the mobile platform. In the more general case where the two interfering rays would leave one after the other the points a and b , a reasoning similar to preceding shows that the points M' and M'' would not be colinear any more, but the conclusion given above would be always valid.

Lastly, it is advisable to point out the possible existence of an aberration effect along the vertical paths FG and JI of figure 6. But the linear velocity of the actuated mirrors F and J not exceeding in our experiments 9 m/sec, the obliqueness which could affect the rays FG or JI only reaches 6 thousandth of an arc second, and is considered here as completely negligible.

In short, with the device thus implemented, any modification in the appearance and the position of fringes when the angular velocity of the platform is in one direction or the other, is extremely small.

It follows that if the experiments, made when the angular velocity is significant, give a fringe variation on the photographic plate fixed on the mobile disc, we will seek the cause in the influence of the speed of the disc compared to the laboratory in which it turns.

3. Experimental results. –

We have carried out under the preceding conditions, two series of recordings, angle FCJ being equal to 120 degrees.

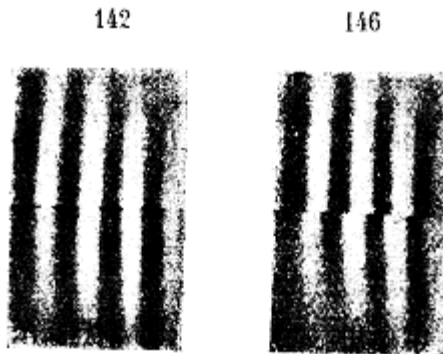

Fig. 9.

The second series differs from the first only by positions of the vertical mirrors of the upper floor. The number of revolutions varied from 1.43 to 4 turns/sec. The successive runs in the opposite direction of rotation were crossed so as to eliminate as much as possible the accidental variations in the fringes during the 5 min in each run for a direction of rotation. The source of light remained as previously a carbon arc. The plates were the same ones as above, of Agfa panchromatic sensitive.

Photograph 146 of figure 9 represents, increased four times, one of the recordings carried out, the number of revolutions being approximately 3.6 turns/sec. The fringes on top and those on the bottom of this test correspond respectively to opposite directions of rotation of mobile platform Δ . The shift of the two systems of fringes, not seen in photograph 142 obtained when the speed of rotation is negligible, is on the contrary very apparent for photograph 146 corresponding to a significant angular velocity.

Measurements of the various photographs used, made with a dividing machine, provided the following results expressing in distances between interference fringes the mutual shift δ of two systems of fringes for the two directions of rotation and a velocity angular of 1 turn/sec for the mobile platform. The first series of experiments gave us δ , with an average of measurements of 15 recordings, the value $\delta = 0.058$. The second series made up of 7 recordings, provided the value $\delta = 0.054$. In the first series, the individual values δ were spread out between 0.052 minimum value and 0.071 maximum value. Those of the second series, not as good as the first, were between 0.046 minimum value and 0.078 maximum value.

These experiments thus highlight the existence, under these conditions, of a shift of the fringes of approximately 0.056 distance between interference fringes in white light, for the two directions of rotation and an angular speed of 1 turn/second. Although the precision of the operations does not allow us to exceed the approximation of a few percent on the median value, the phenomenon is beyond doubt and its cause must be sought in the influence of the number of revolutions of the platform on the propagation of

light, using the various possible interpretations. That is what we are going to consider now.

III. - Interpretation of the experimental results.

Let us point out initially the elements of the theories that we will apply here. The classical theory supposes, as one knows, that for the observer linked (fixed) to the disc, the speed of the light in a point of the revolving disc differs from the speed C of the light in the laboratory, in a quantity equal to $+/- v$, if v represents in value the absolute projection of the linear velocity of the disk at the point considered on the platform, the element of the path considered. We will use as the relativistic theory of these phenomena, that given by Mr. Langevin [2] in 1921 and recalled by him more recently [3]. In this form of interpretation, the observer is pulled by the moving disc and is supposed to adopt a central time t which is that reported by the Galilean observer in which the center O is chosen on the platform as motionless. (Let us notice while passing that this selected center O is not necessarily the center C of rotation of the platform, but that it is an unspecified point, arbitrarily chosen on the disc.) The form which takes the fundamental invariant ds^2 implies an anisotropy in light propagation of which the speed varies with direction between $C + \omega r$ and $C - \omega r$ with the first order of approximation in ω . In these expressions, ω is the angular velocity of rotation of the platform, r is the distance from center O arbitrarily chosen, at the point of passage, on the disc, of the light ray considered. Mr. Langevin finds thus that duration dt of light course of length dl is given for a direction of circulation of the light by expression: $dt = \frac{dl}{C} + \frac{2\omega}{C^2} dA$

where dA is the area of a triangle with base dl and top selected arbitrary center O . While integrating along the finished light course fixed to the revolving disc, and by taking account of the other direction of propagation, one can deduce the value from the displacement of the fringes ascribable to the course considered.

Ultimately, the two theories lead, as one knows, to the following predictions respectively concerning the united finished trip on the turning disk: the awaited shift of the fringes is, all things being equal, proportional to an area having for its base the path traversed by the light on the mobile platform, but on which the top of the path is not the same one for these two theories: in classical theory, this top is the center of the rotation point C on the platform, and is independent of the position of point O , where the traditional observer is supposed to be fixed to the mobile platform; according to the relativistic theory, this top is arbitrary; we choose it, just like, on the beamsplitter S at same point O , where we are also supposed to place the relativistic observer fixed to the mobile platform.

We then have to apply these considerations with the following two cases:

1° The optical circuit, closed, is in its entirety fixed to the revolving disc. ---

This is the well-known case of experiments of Sagnac. The two theories are here in agreement between them and in agreement with the experiment, with regard to the total shift of the 8 fringes recorded on the disc turning. However, the traditional theorist and the relativistic theorist are not in agreement between them on the distribution that they make, of the cause of the phenomenon, between the various components of the total course. But so that the physicist operator who makes the experiment has the possibility of choosing between these two theoretical interpretations, it would be necessary to take an experimental measurement directly of the speed of light on the platform in rotation, an operation which is obviously impossible to realize with the precision necessary, in the current state of the art.

2° Part of optical circuit is fixed to the revolving disc, the other part of the optical circuit remains fixed compared to the laboratory. –

Under these conditions, which are those of our experiments, the shift of the fringes is due obviously to the optical course fixed to the revolving disc. We will calculate the values which return to us according to the two theories.

In the experiments made in accordance with assembly of figure 6, the area included in the sector having for base the light path trained FDEOKJ and for top of the path the center C of rotation of the platform had as an algebraic full value (because the surface of the small basic triangle base ED in this figure must be counted as negative), $A' = 1777 \text{ cm}^2$ approximately, while the area of that of the same sector based light path FDEOKJ and whose top is the item 0 where the observer is pulled by the disc, had as an algebraic full value:

$$A = 169 \text{ cm}^2 \text{ approximately}$$

By introducing these numerical values into the expression of the fringe shifts δ , one finds with $\lambda = 0.56 \text{ um}$, for the two directions of rotation and for an angular velocity of 1 turn/sec,

$$\delta = \frac{16 - A'}{e\lambda} = 0.053 \text{ in fringes} \quad (\text{according to the classical theory})$$

$$\delta = \frac{16 - A'}{e\lambda} = 0.005 \text{ in fringes} \quad (\text{according to the relativistic theory});$$

that is to say a value that is approximately ten times smaller, according to this last theory than according to the preceding one.

The relativistic theory thus seems to be in complete dissention with the classical theory and also with the result provided by this experiment. But given that, as the note of Mr. Largevin appeared to allow the value to be reported higher, we have considered that the center where the theoretical relativist must be presumedly placed can be arbitrarily selected. The relativistic theory is found contrary to agreement with the classical theory and the experiment if this center is obligatorily colinear with the center of rotation of the disc, the only point on the disc which can be the permanent origin of Galilean axes not subjected to the rotational movement of the unit. This is despite the explanation that Mr.

Langevin said to us, and which he arrived at after having been informed of the result of our experiments.

BIBLIOGRAPHY.

- [1] SAGNAC, Journal de Physique, 1914, t. 4, p. 177.
- [2] LANGEVIN, C. R. Acad. Sci., 1921, t. 173, p. 831.
- [3] LANGEVIN, C. R. Acad. Sci., 1937, t. 205, p. 304.

Note:

Mr. Langevin points out to us that, observers related to an unspecified point 0 on the revolving disc can be regarded as motionless when they are first order experiments according to the angular velocity of rotation ω and it is the point of view at which he placed himself in his Notes of 1921 and of 1937, they must on the contrary, in classical theory as in relativity, to take account of their distance r with the axis of rotation C when they are experiments of second order, or when, as in the experiments in question here, the experimental device is only partly related to the revolving disc. If one wants, in relativistic theory, to place from the point of view of observers 0, it is necessary to consider the part of the device external to the disc, as, with the first order, being animated by a translatory movement speed ωr . The reasoning which supposes this part motionless requires that the observers be related to the center C .